

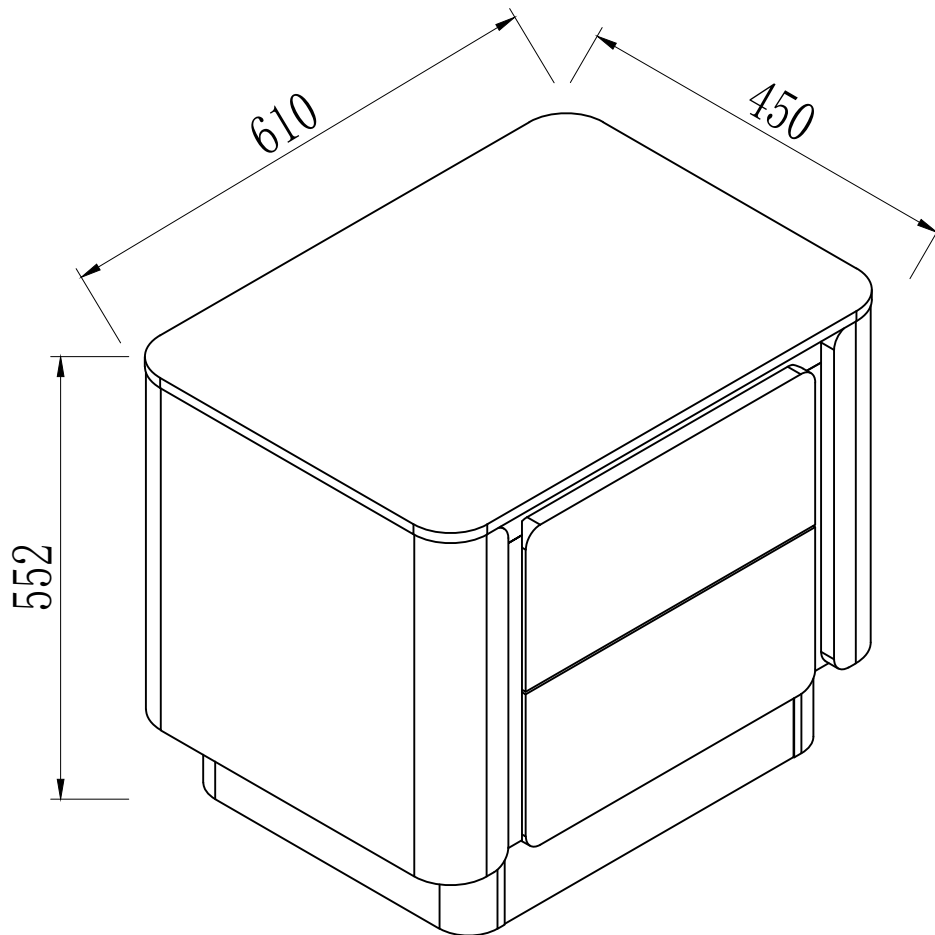

ASSEMBLY INSTRUCTION
VINCENTIO BEDSIDE
ITEM CODE 85548





Imported by Amart Furniture Pty Ltd. Qld. Brisbane Australia.
For any assistance with assembly or for missing parts please phone Amart Furniture
Customer Service Free call 1800 351 084

PRE-ASSEMBLY PREPARATION

Before you start:

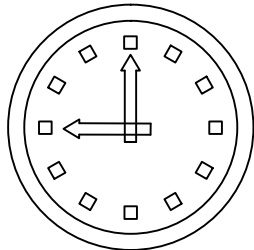
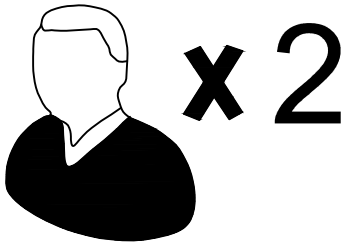
1. Choose a clean, level, spacious assembly area. Avoid hard surfaces that may damage the product
2. Take care when lifting. Product should be assembled as near as possible to the point of use
3. Ensure that you have all required contents for complete assembly.
4. Always read the assembly instructions carefully before beginning assembly.
5. Keep all hardware parts and packaging out of reach of small children.
6. Do not over tighten the screws and bolts as this may damage the threads







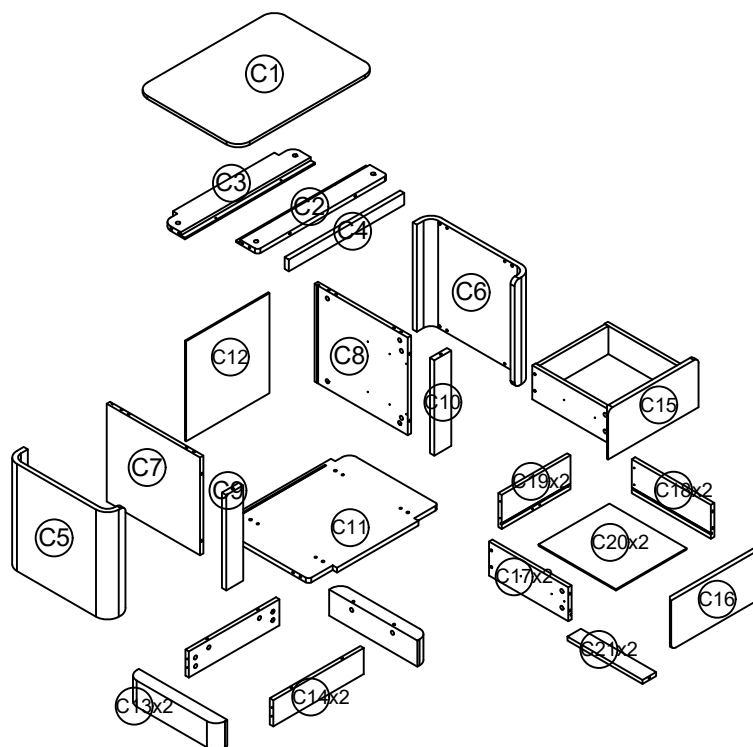

| | |
|---|--|
|  <p>ALLOW 45 MINUTES</p> |  <p>2 PEOPLE REQUIRED</p> |
|  <p>⊕</p> <p>ADDITIONAL TOOLS REQUIRED</p> | |

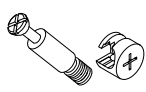
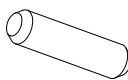
| ⚠ WARNING | | |
|---|---|---|
|  |  | <p>Children have died from furniture tipover.</p> <ul style="list-style-type: none">• ALWAYS secure it with an anchor device.• NEVER allow children to stand, climb or hang on drawers, doors, or shelves.• NEVER open more than one drawer at a time.• Place heavy items down low <p>NEVER put a TV on this furniture </p> <p>This is a permanent label. Do not remove!</p> |

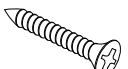
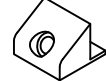
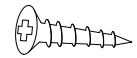
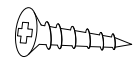
PARTS LIST



| | | | |
|-----|--------------------|-------|-------------------------|
| C1 | Top Panel | C12 | Back panel |
| C2 | Top Rail | C13x2 | Leg panel |
| C3 | Top Rail | C14x2 | Leg panel |
| C4 | Front Rail | C15 | Drawer Front panel |
| C5 | Left Side Panel | C16 | Drawer Front panel |
| C6 | Right Side Panel | C17x2 | Drawer Left Side panel |
| C7 | Left Inside Panel | C18x2 | Drawer Right Side panel |
| C8 | Right Inside Panel | C19x2 | Drawer Back panel |
| C9 | Left Front Panel | C20x2 | Drawer Bottom panel |
| C10 | Right Front Panel | C21x2 | Drawer Support panel |
| C11 | Bottom Panel | | |

| | | | | | | |
|--|--|---|---|---|--|--|
| <input type="checkbox"/> A. Cam lock and Cam pin Ø15X35  50PCS | <input type="checkbox"/> B. Dowel Ø8x30  20PCS | <input type="checkbox"/> C. Screw Ø3.5x12  24PCS | <input type="checkbox"/> D. Screw Ø3.5x30  12PCS | <input type="checkbox"/> E. Connector 18x16x10  4PCS | <input type="checkbox"/> F. Screw Ø3x18  4PCS | <input type="checkbox"/> G. Screw M4x16  4PCS |
| <input type="checkbox"/> H. Anti-collision Ø10  4PCS | <input type="checkbox"/> I. Protect Foam Ø35X5mm  4PCS | <input type="checkbox"/> J. GLUE  1PCS | <input type="checkbox"/> K. Runner 250mm  2PCS | <input type="checkbox"/> L. Safety Bracket Kit  1PCS | | |

85548

STEP 1:

Runner slide separately ($K=K1+K2$)

Carefully pull out the runner slide ($K2$) and press plastic clip to fully separate runner slide as diagram shown

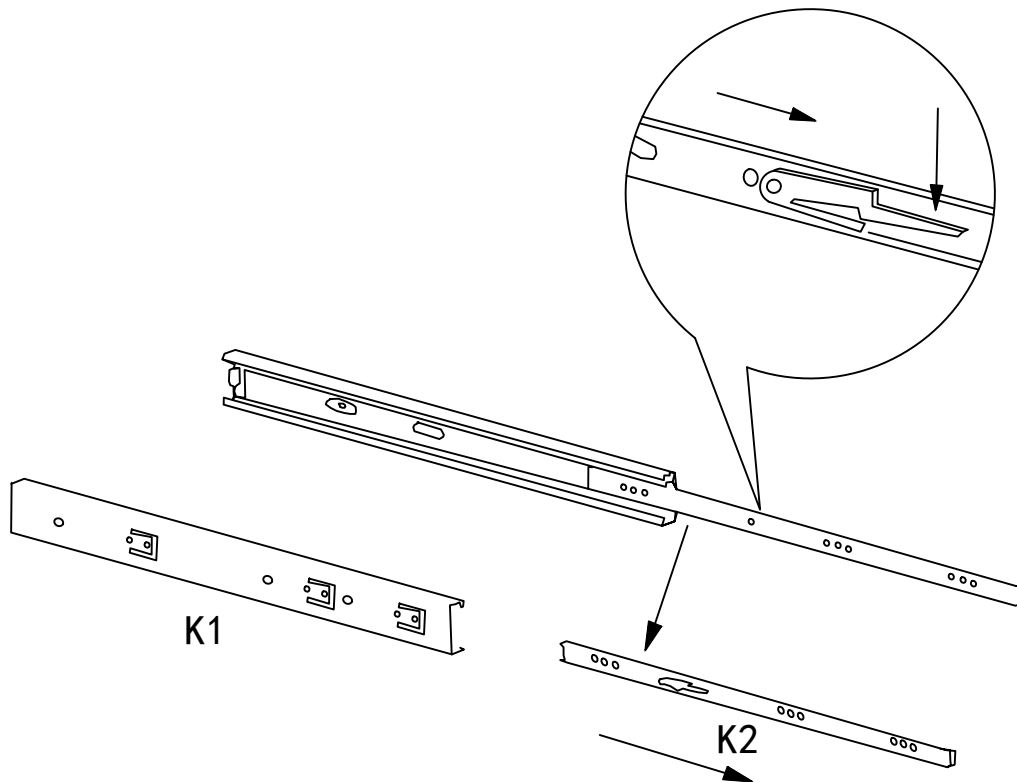

STEP 2: Use a Phillips Head Screwdriver to attach Cam Pin(A) to the Panel(C2,C3,C4,C5,C6,C9,C10,C13,C15,C16). Insert Dowel(B) to the Panel(C2,C3) with Glue(J).

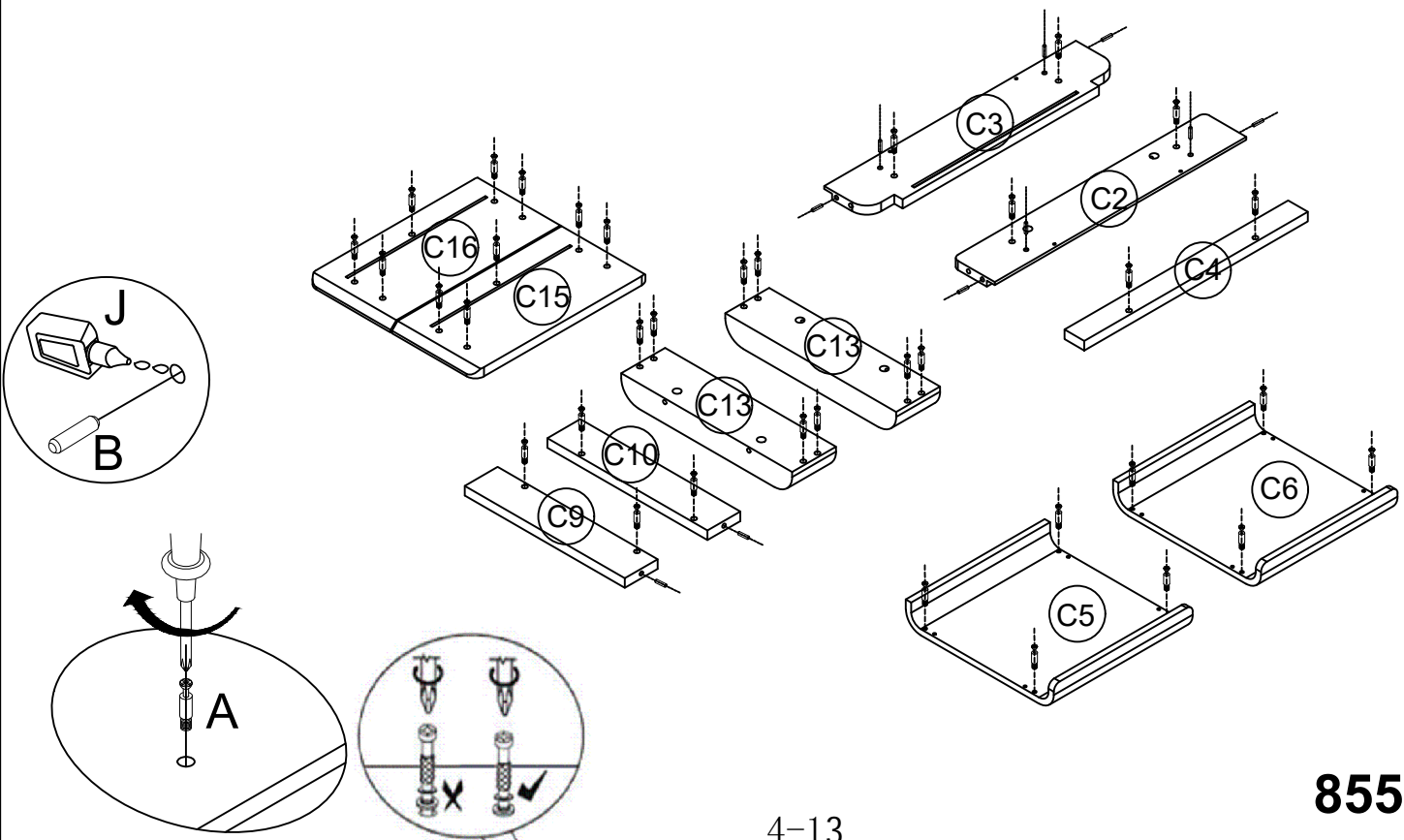

85548

STEP 3: Use a Phillips Head Screwdriver to attach Cam Pin(A) to Panel(C11), Insert the Dowel(B) to the Panel(C7,C8) with Gule(J). attached Runner(K1) to the Panel(C7,C8) with Screw(C).

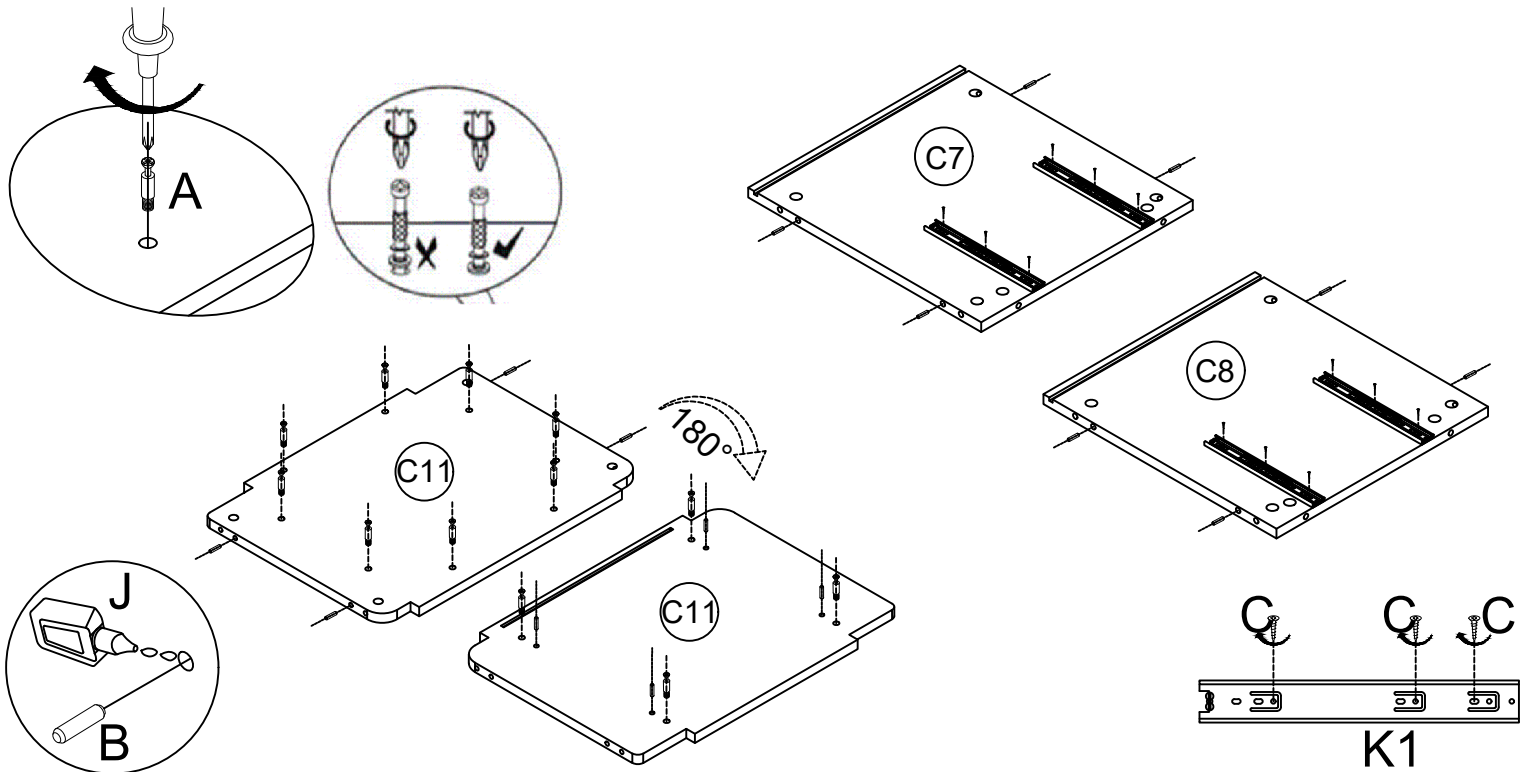

STEP 4: Use a Phillips Head Screwdriver to assemble Panel (C13) to the Panel(C14) with Cam Lock(A).

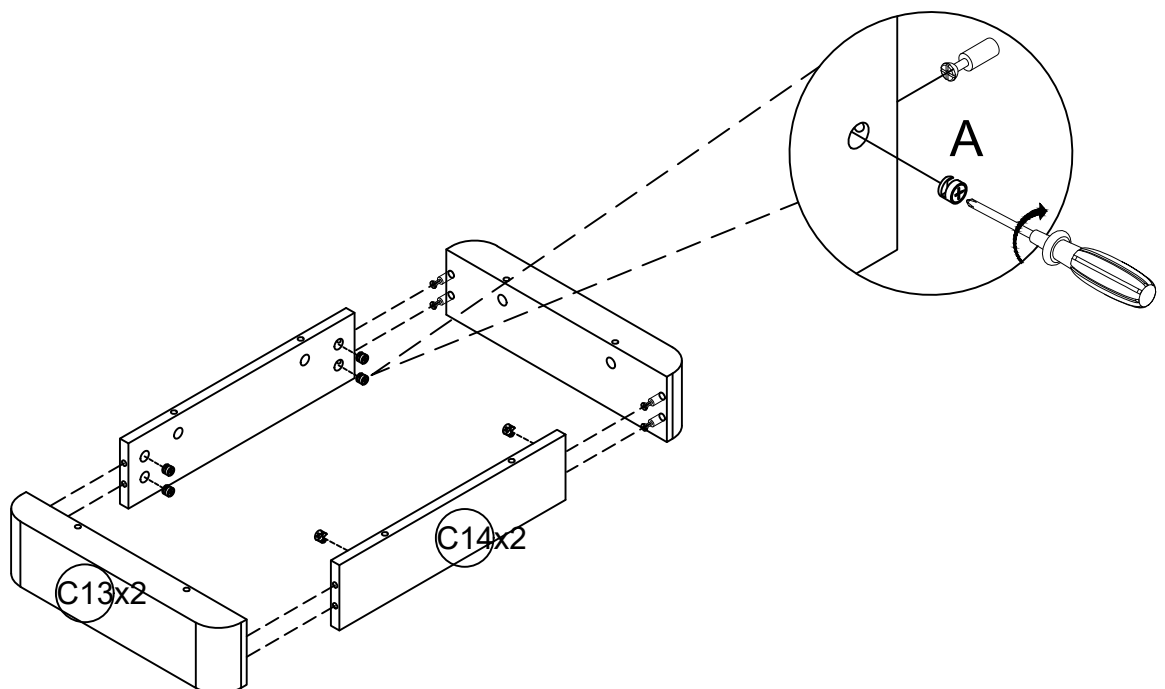

85548

STEP 5: Use a Phillips Head Screwdriver to assemble Panel (C13,C14) to the Panel(C11) with Cam Lock(A).Stick Protest Foam(I) to the Panel(C13).

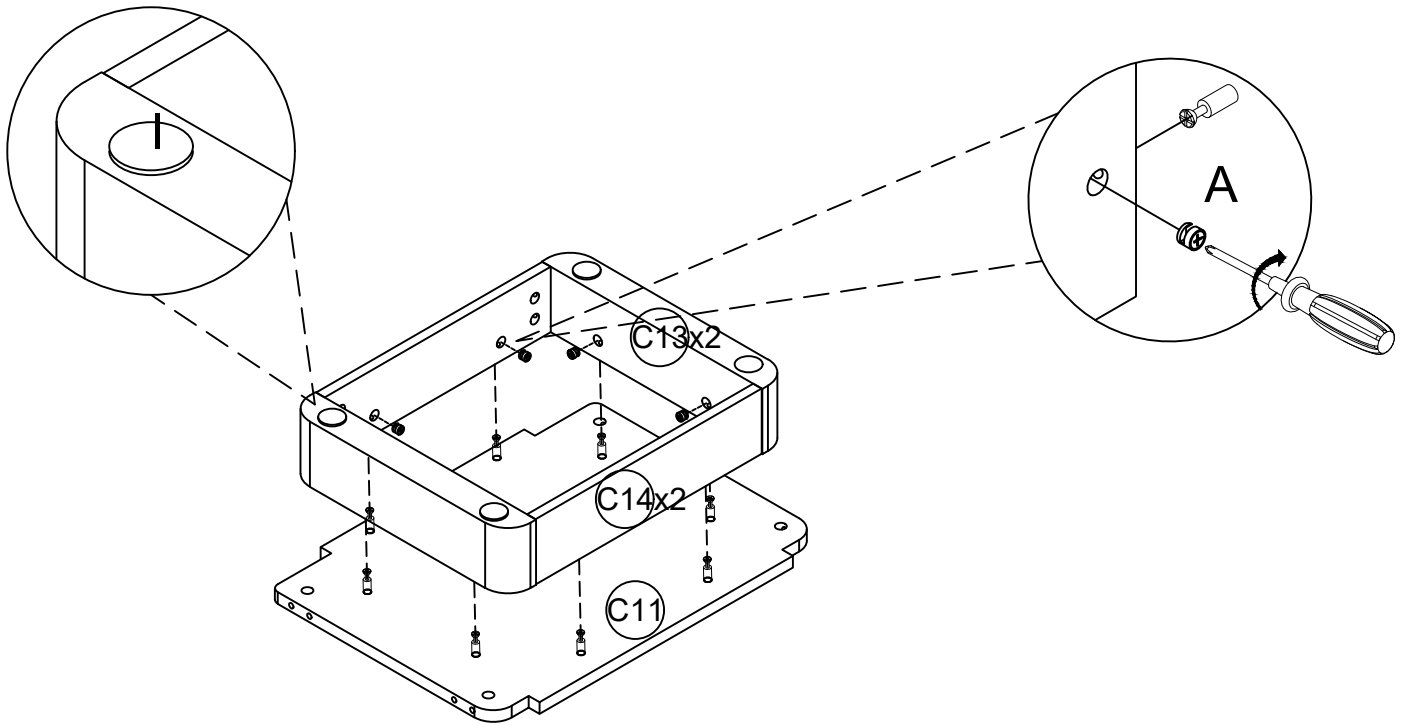

STEP 6: Use a Phillips Head Screwdriver to assemble Panel (C7,C8) to the Panel(C11) with Cam Lock(A).assemble Panel(C9) to the Panle(C7),assemble Panel(C10) to the Panel(C8) with Cam Lock(A).

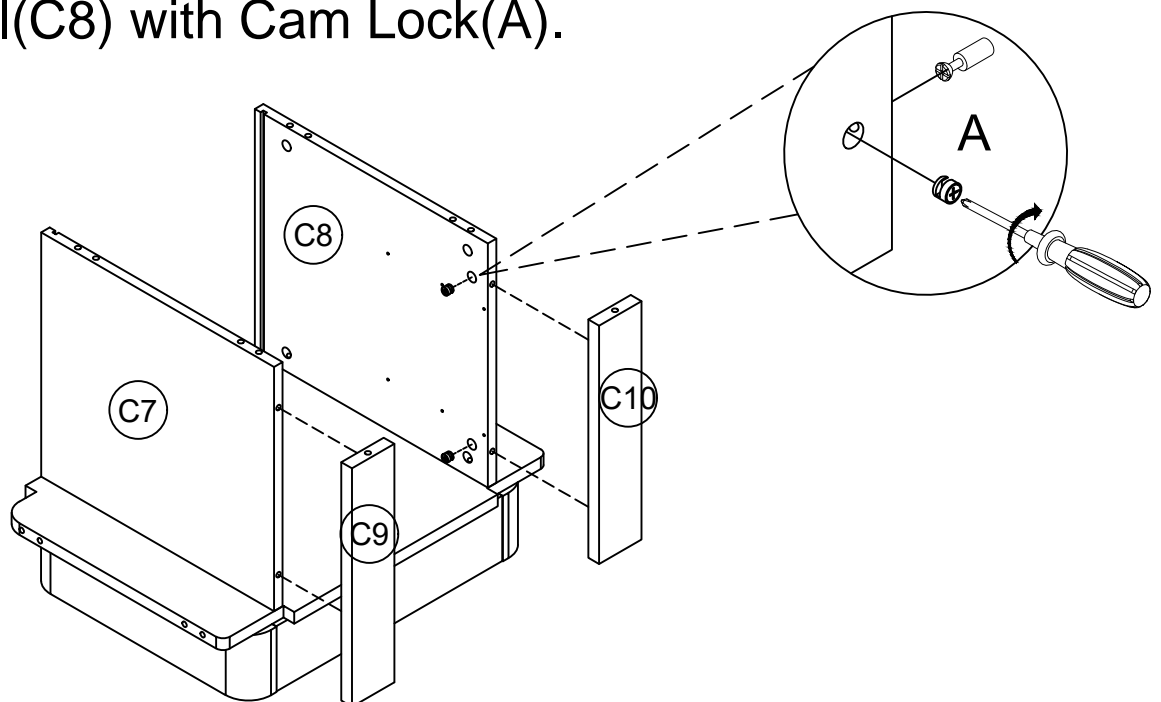

85548

STEP 7: Insert the Back Panel(C12) to the groove, Use a Phillips Head Screwdriver to assemble Panel(C2,C4,C3) to the Panel(C7,C8,C9,C10) with Cam Lock(A).

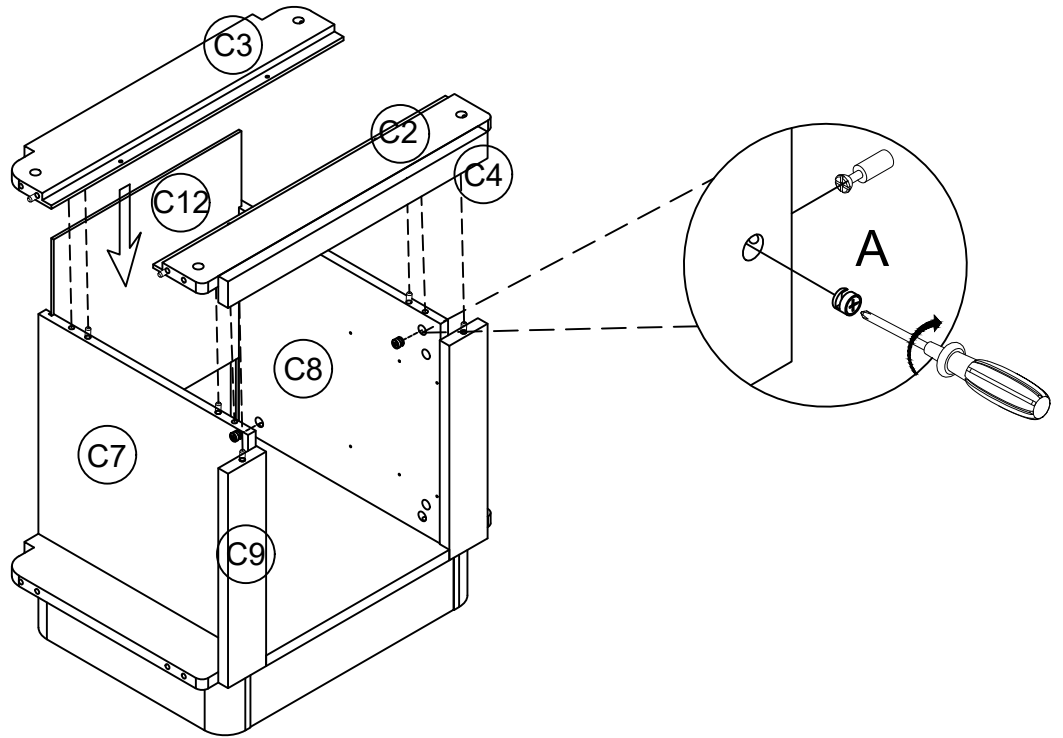

STEP 8: Use a Phillips Head Screwdriver to assemble Panel(C5) to the Panel(C7) with Cam Lock(A), assemble Panel(C6) to the Panel (C8) with Cam Lock(A). assemble Panel(C1) to Panel(C2,C3) with Screw(G).

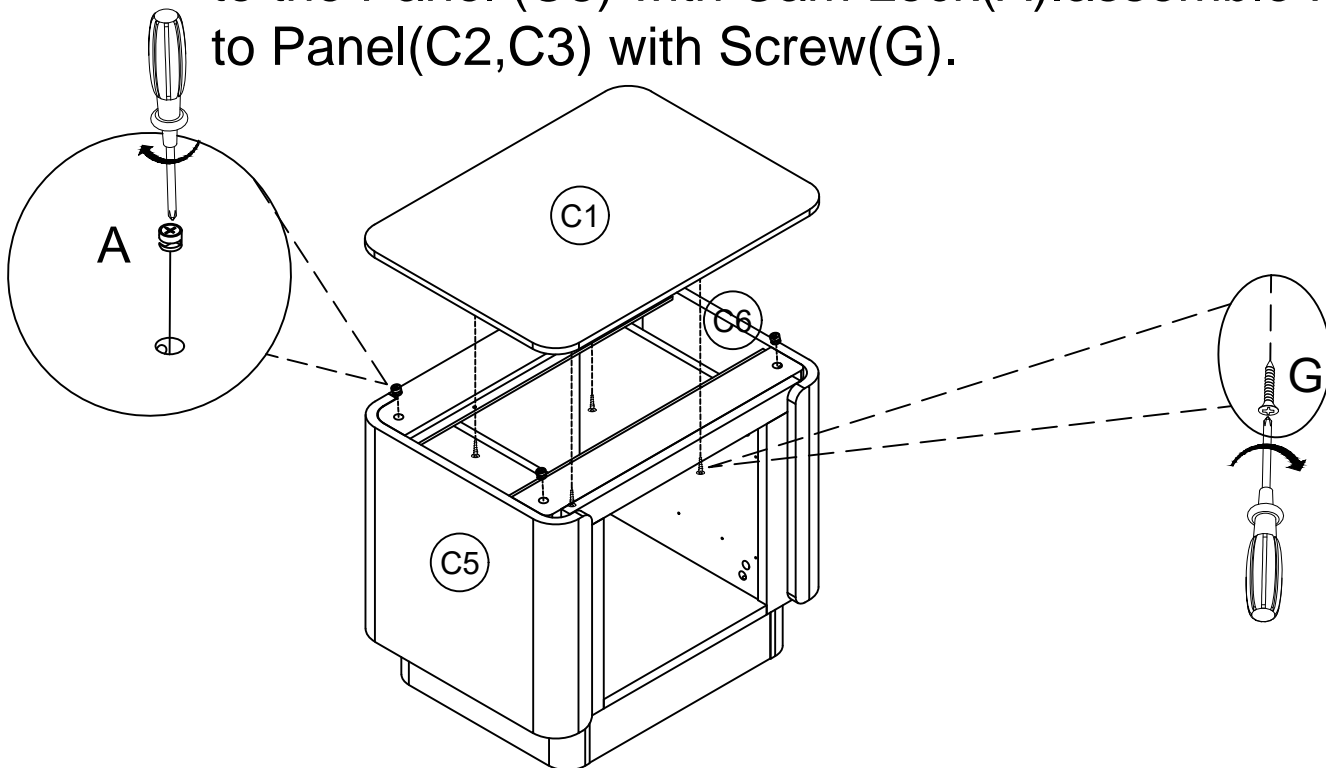

85548

STEP 9: Use a Phillips Head Screwdriver to assemble Connector(E) to the Back Corner with Screw(F).

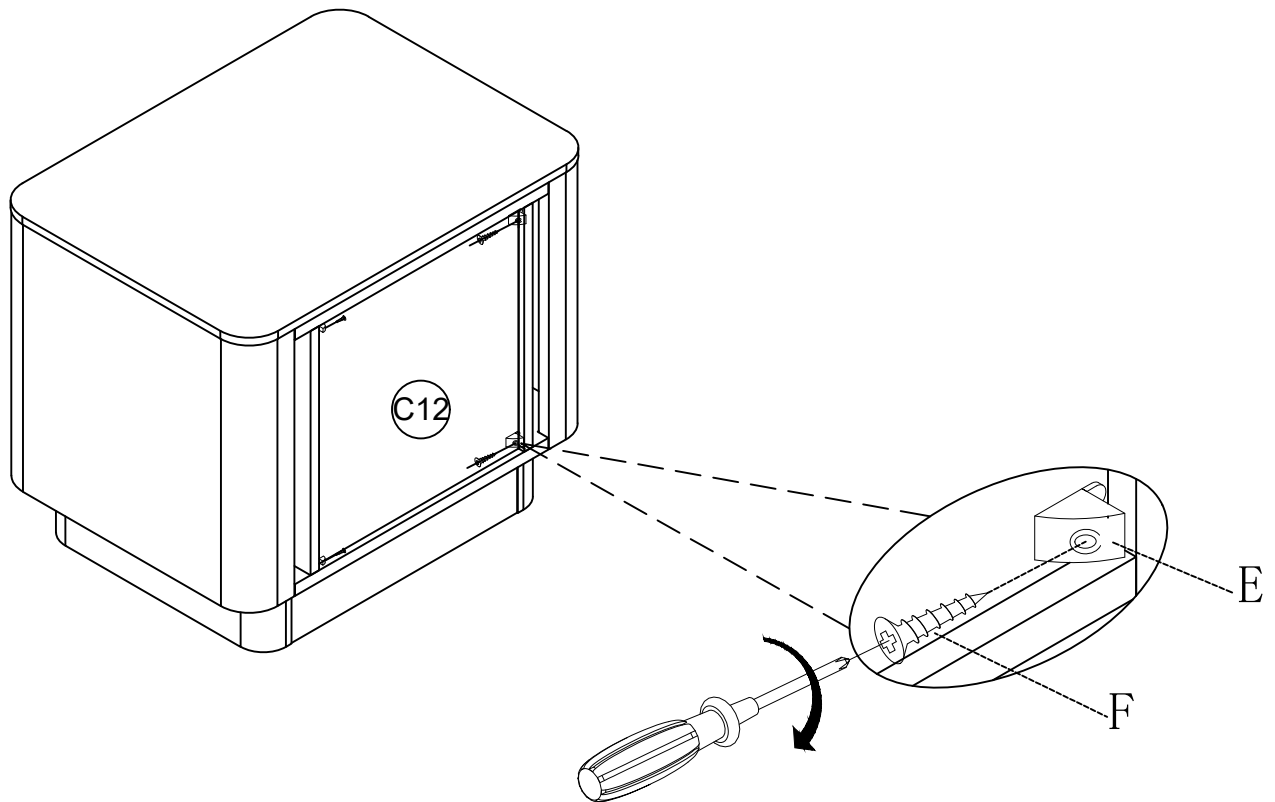

STEP 10: Use a Phillips Head Screwdriver to attach Runner(K2) to the Panel(C17,C18) with Screw(C).assemble Panel (C17,C18,C21) to the Drawer Back Panel(C19) with Screw(D).

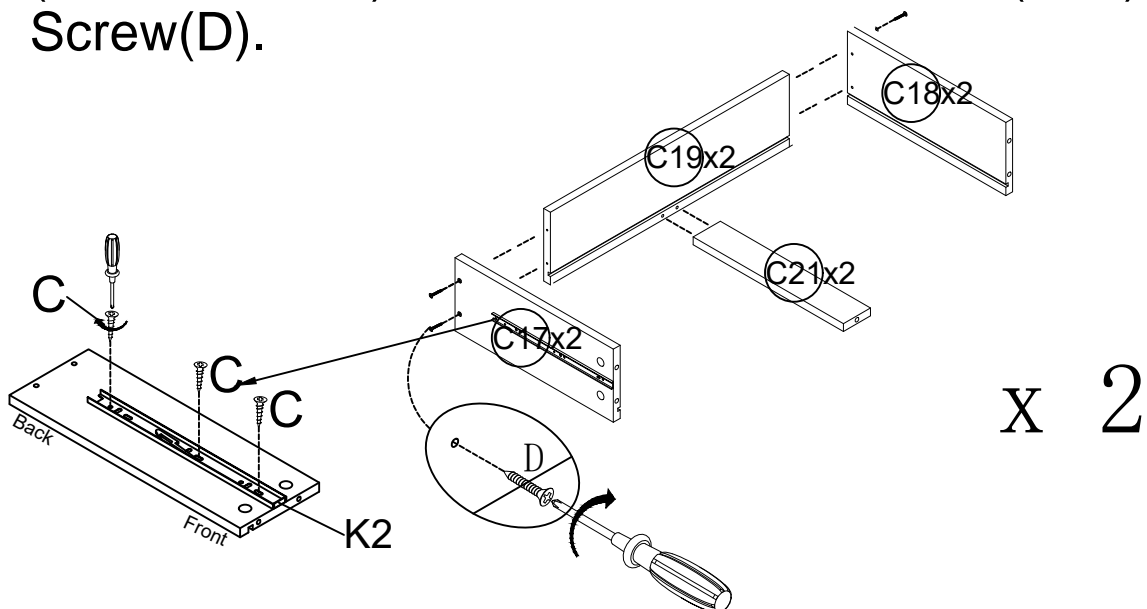

STEP 11: Insert the Drawer Bottom Panel(C20) to the groove, Use a Phillips Head Screwdriver to assemble Panel(C17,C18,C21) to the Drawer Front Panel(C15) with Cam Lock(A).

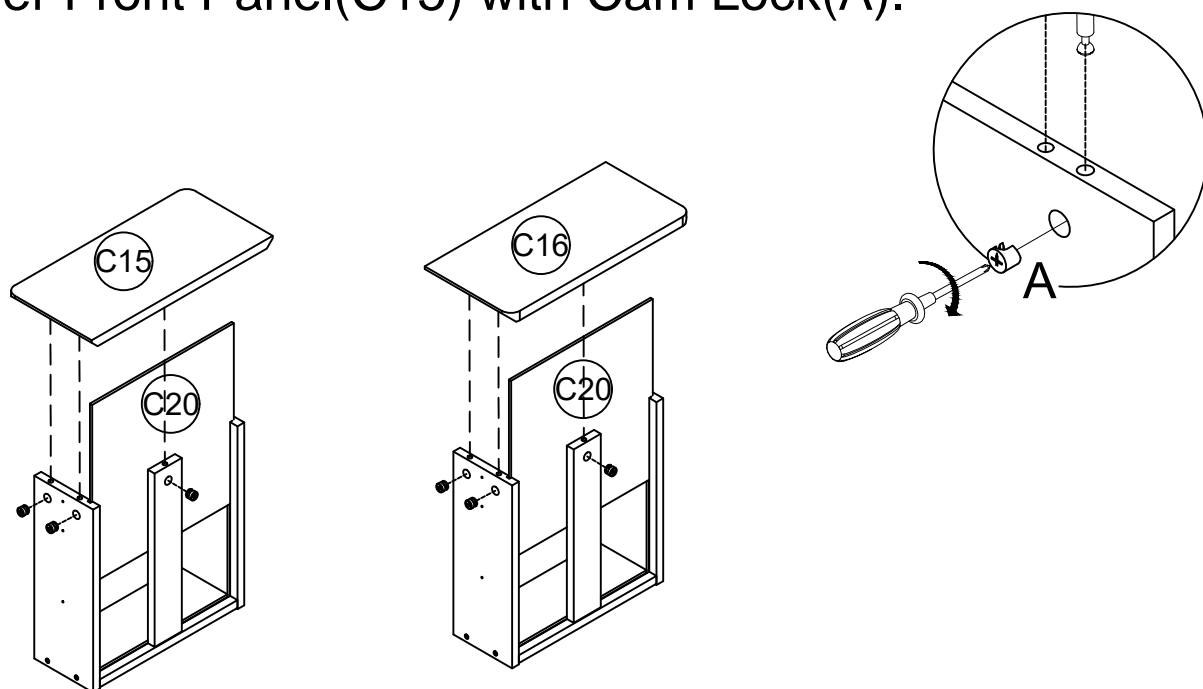

STEP 12: Insert the drawers into the body. Stick the Anti-Collision (H) to inside of the Drawer Front Panel

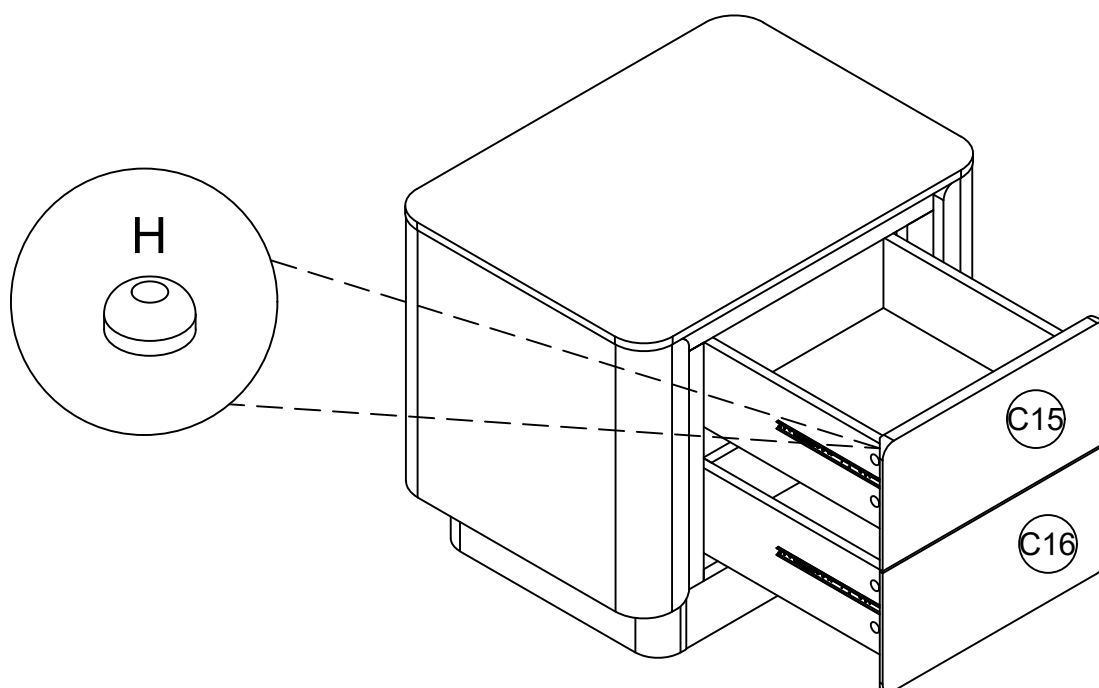

SAFETY BRACKETS INSTRUCTIONS

This furniture poses a tipping risk and as such must be secured to a wall using the provided tipping kit.

1. Attach one Mounting Plate to the wall with the Large Screws. Make sure to attach the Mounting Plate into a stud. If mounting into brick or masonry you will need to acquire wall anchors. Please enquire with your local hardware supplier for appropriate fixings.
2. Attach the second Mounting Plate to the furniture frame with the Short Screws.
3. Move the furniture to its final position. Thread a Wall Strap through the both Mounting Plates and tighten until snug. Do not over tighten.
4. Make sure that the Mounting Plates are firmly attached to the wall and furniture and that the Wall Strap is snug.

HARDWARE



Mounting Plate x 2



Wall Strap x 1



Large Screw x2



Small Screw x2

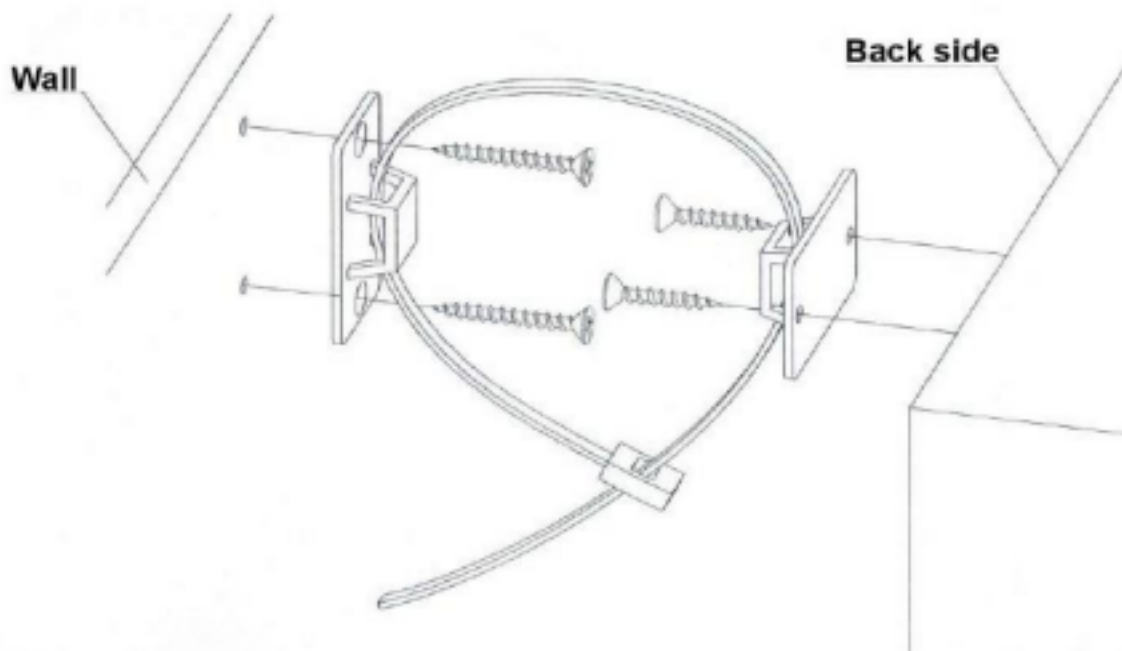

Assembly is complete

CAUTION:

**ALWAYS LIFT YOUR PRODUCT WHEN MOVING/RELOCATING.
DO NOT DRAG. DRAGGING CAN CAUSE DAMAGE TO THE
LEGS**

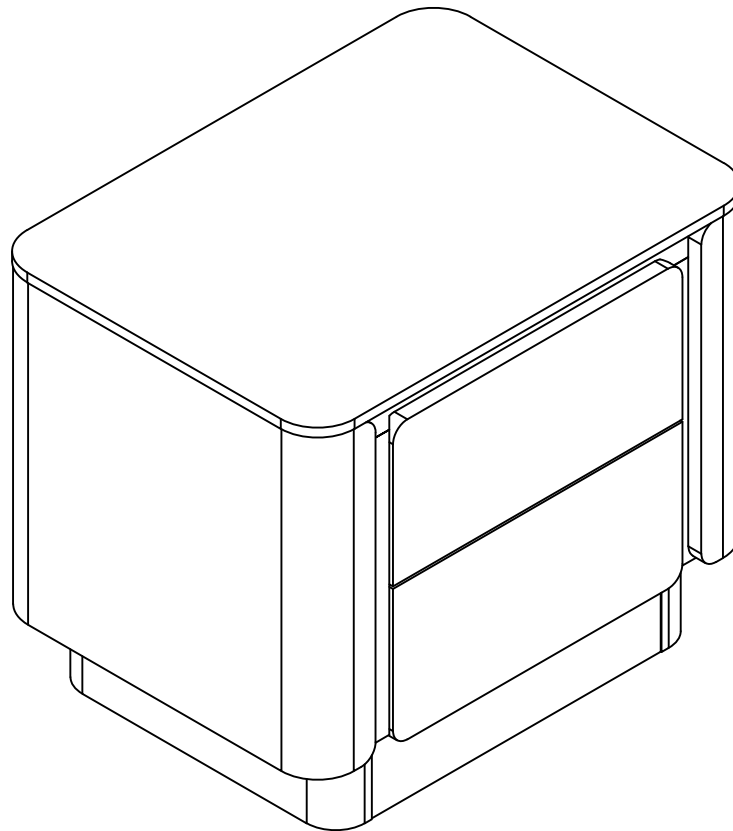

Note -

Do not drag the furniture as this may cause damage to the legs. Instead, use 2 persons to lift carefully from either end.

Product Care for Timber Items

As our timber is supplied from sustainable forests there will be natural variations in surface texture and grain like knots, mineral streaks and sap runs that may affect the finish. These differences in character are not defects, but distinctions that make each piece of furniture unique

Our furniture is built to last. Following these steps for basic care should protect your investment for years to come

- Dust frequently with a clean damp lint-free cloth. This will help remove abrasive build up which can damage a finish over time
- Do not place hot objects on any furniture surface. Always use a hot plate or placemat. Laminate and lacquer finishes on table tops provide added scratch and heat resistance to our furniture, but they can still be damaged without proper care
- Avoid exposing your furniture to strong sunlight, heat outlet, open windows or dampness. Prolonged exposure to direct sunlight can fade the finish of your furniture, while extreme temperature and humidity changes can cause cracking or splitting
- Do not expose your furniture to any liquids. Never allow water to sit on your furniture. Alcohol, nail polish and perfume are also dangerous as they will dissolve the lacquer finish on contact and may require professional repairs
- Do not allow plastic to come in direct contact with your furniture. Chemicals in the plastic of placemats etc. may soften and mark the finish if left in contact with the furniture for a period of time

Product Care for Sintered Stone Items

Daily Cleaning

•
General Stain Removal: As the surface of sintered stone furniture is non - porous and non - absorbent, for daily cleaning, simply wiping with a soft, damp cloth can remove dust and light stains such as coffee stains and fruit juice stains. For more stubborn stains, a mild detergent can be used. However, avoid using cleaners that contain strong acids, strong alkalis, or abrasive components to prevent damage to the furniture surface.

•Preventing Water Stain Residue: After cleaning, wipe off the water in a timely manner to prevent water stain residue. Because long - term water stains may form water marks on the surface and affect the appearance.

Avoid Scratching and Collision

•
Careful Use: In daily use, avoid using sharp objects such as knives and keys to scratch on the furniture surface, as this may cause scratches. Although sintered stone is relatively wear - resistant, sharp objects can still damage its surface.

•Pay Attention to Moving: When moving furniture, handle it with care and avoid collision with other hard objects. If you need to move heavy sintered stone furniture, it's best to ask professionals for help to prevent accidental collisions during the moving process and damage to the furniture.

Prevent Chemical Corrosion

•
Avoid Contact with Acid - Base Substances: Sintered stone furniture should avoid contact with acidic or alkaline chemicals such as vinegar, lemon juice, and bleach. These substances may react chemically with the stone, causing the surface to discolor, corrode, or be damaged.

•Choose Cleaners Carefully: When choosing a cleaner, carefully check the product ingredients to ensure that it will not damage the sintered stone. If you're not sure whether a cleaner is suitable, you can first conduct a small - area test on an inconspicuous part of the furniture and observe whether there is any adverse reaction before using it.